

SVORKA NA POTRUBÍ

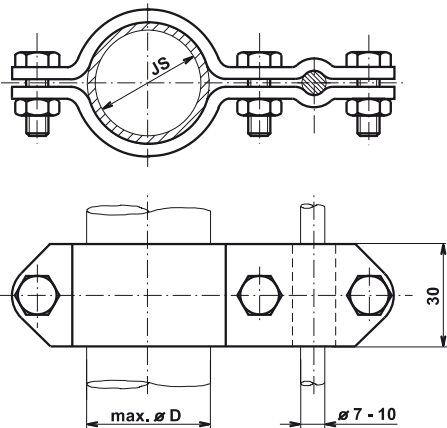

Provedení	Označení	øD (mm)	Js (")	Hmotnost (kg)	Balení (ks)	Kód
Fe/Zn	ST 1	18 - 22	1/2	0,208	50	V096
	ST 2	23 - 27	3/4	0,255	50	V097
	ST 3	28 - 34	1	0,275	50	V098
	ST 4	35 - 43	1 1/4	0,295	50	V099
	ST 5	44 - 49	1 1/2	0,315	50	V100
	ST 6	50 - 61	2	0,345	50	V101
	ST 7	67 - 77	2 1/2	0,373	50	V102
	ST 8	81 - 90	3	0,405	50	V103
	ST 9	106 - 115	4	0,497	50	V104
Měď	ST 1 Cu	18 - 22	1/2	0,237	1	V691
	ST 2 Cu	23 - 27	3/4	0,289	1	V692
	ST 3 Cu	28 - 34	1	0,313	1	V693
	ST 4 Cu	35 - 43	1 1/4	0,336	1	V694
Nerez	ST 1 N	18 - 22	1/2	0,167	1	VN2081
	ST 2 N	23 - 27	3/4	0,203	1	VN2082
	ST 3 N	28 - 34	1	0,218	1	VN2083
	ST 4 N	35 - 43	1 1/4	0,233	1	VN2084
	ST 5 N	44 - 49	1 1/2	0,248	1	VN2085
	ST 6 N	50 - 61	2	0,271	1	VN2086
	ST 7 N	67 - 77	2 1/2	0,292	1	VN2087
	ST 8 N	81 - 90	3	0,315	1	VN2088
	ST 9 N	106 - 115	4	0,384	1	VN2089

Použití: Spojování potrubí a okapových svodů s kruhovým vodičem.