



WB-S

Dodávané průměry :

WB-S Ø210
WB-S Ø240
WB-S Ø310

Ventilátor řady WB-S je vyroben z galvanizovaného ocelového plechu, který je práškově lakován.

Vrtule je z hliníku.

Výrobek je vhodný pro nástěnnou ventilaci menších místností jako jsou sklady a malé průmyslové objekty.

ROZMĚRY VÝROBKU

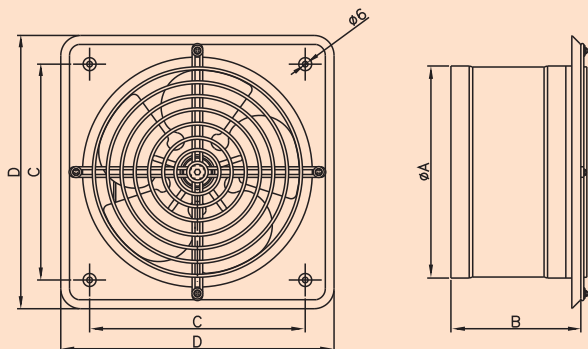

	ØA	B	C	D
WB - S Ø210	211	135	215	274
WB - S Ø240	243	135	240	298
WB - S Ø310	311	172	315	370

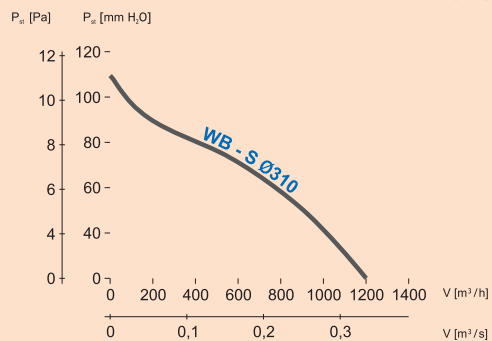
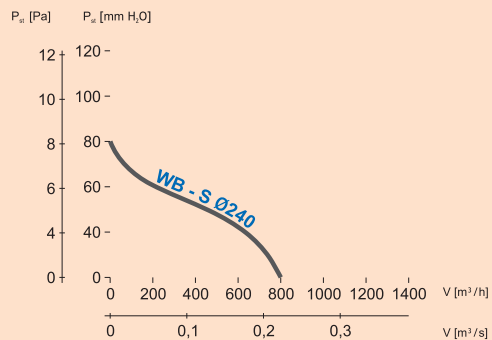
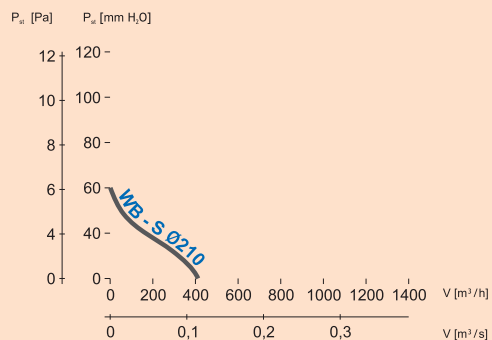

TECHNICKÁ DATA

Model	Air flow [m³/h]	Static pressure [Pa]	Static pressure [mmH ₂ O]	Acoustic pressure [dB(A) m]	Power supply voltage [V/Hz]	Motor speed [rpm]	Power [W]	Power consumption [A]	Max. working temperature [°C]	Weight [kg]	Motor protection rated [IP]	Insulation class
WB - S Ø210	410	60	6,12	54	230/50	1400	45	0,24	42	2,4	X2	I
WB - S Ø240	800	80	8,15	57	230/50	1400	55	0,46	42	4,2	X2	I
WB - S Ø310	1200	108	11,01	62	230/50	1400	70	0,75	42	5,0	X2	I