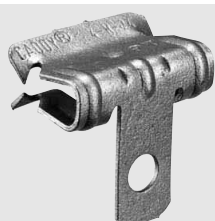
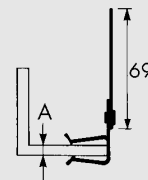
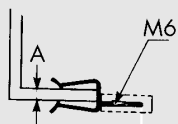

CADDY**2. UPEVŇOVACÍ PRVKY****H-PŘÍCHYTKA**

Obj.č.	A mm	kg/NS	Kus			
			kg/NS	Kč	kg	
P4						
2H4	170010	2-3	100	70	12,00	0,013
4H24	170020	3-8	100	90	13,20	0,013
4H58	170030	8-14	100	90	14,40	0,015
4H912	170040	14-20	100	90	15,60	0,018

**H-ST PŘÍCHYTKA**

Obj.č.	A mm	kg/NS	Kus			
			kg/NS	Kč	kg	
P4 - EPZ						
2H4ST3	173420	2-3	100		38,40	0,021
4H24ST3	171500	3-8	100		37,80	0,026
4H58ST3	171530	8-14	100		40,30	0,029
4H912ST3	171640	14-20	100		39,80	0,031

**H-i PŘÍCHYTKA**

Obj.č.	A mm	kg/NS	Kus			
			kg/NS	Kč	kg	
P4 - EPZ						
4H24i	170150	3-8	100	15	16,60	0,015
4H58i	170250	8-14	100	15	17,80	0,017

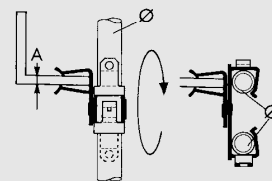
**H-MAC2 PŘÍCHYTKA**

Obj.č.	A mm	Ø mm	kg/NS	Kus		
				kg/NS	Kč	kg
P4 - EPZ						
2H4MAC2	173110	2-3	12,5-14,5	100	33,00	0,019
4H24MAC2	173150	3-8	12,5-14,5	100	36,00	0,025
4H58MAC2	173160	8-14	12,5-14,5	100	39,00	0,025
4H912MAC2	173410	14-20	12,5-14,5	100	39,60	0,025

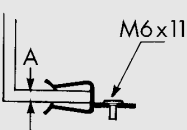
**H-iX PŘÍCHYTKA**

Obj.č.	A mm	kg/NS	Kus			
			kg/NS	Kč	kg	
P4 - EPZ						
4H24iX	170140	3-8	100	15	34,00	0,015
4H58iX	170160	8-14	100	15	35,20	0,017

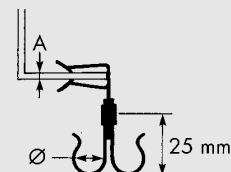
**H-CA/H-CB
PŘÍCHYTKA**

Obj.č.	A mm	Ø mm	mm²	kg/NS	Kus		
					kg/NS	Kč	kg
P4 - EPZ							
2H4/1012A	170460	2-3	10,9-13	70	100	24,00	0,012
4H24/1012A	170480	3-8	10,9-13	70	100	27,60	0,018
2H4/1214A	170470	2-3	12,4-16	95	100	24,60	0,013
4H24/1214A	170630	3-8	12,4-16	95	100	28,80	0,019
P4 - EPZ							
2H4/1012B	170830	2-3	10,9-13	70	100	30,60	0,015
4H24/1012B	170850	3-8	10,9-13	70	100	34,80	0,021
2H4/1214B	170840	2-3	12,4-16	95	100	31,80	0,017
4H24/1214B	170640	3-8	12,4-16	95	100	36,00	0,023

CADDY

H-CT PŘÍCHYTKA

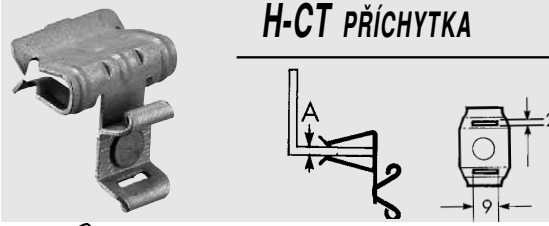

Obj.č.	A mm	Kus	Kus			
			kg/NS	Kč	kg	
P4 - EPZ						
2H4CT	178510	2-3	100	15	32,00	0,016
4H24CT	178520	3-8	100	15	34,00	0,018
4H58CT	178530	8-14	100	15	35,20	0,020
4H912CT	178540	14-20	100	15	36,40	0,022

H-CTB PŘÍCHYTKA



Obj.č.	A mm	B mm	Kus	Kus			
				kg/NS	Kč	kg	
P4 - EPZ							
bílý pásek							
2H4CTBW	170170	2-3	10-70	100	15	40,80	0,016
4H24CTBW	170180	3-8	10-70	100	15	42,30	0,023
4H58CTBW	170190	8-14	10-70	100	15	44,40	0,025
4H912CTBW	170200	14-20	10-70	100	15	45,90	0,027
černý pásek							
2H4CTBB	170210	2-3	10-70	100	15	42,00	0,016
4H24CTBB	170220	3-8	10-70	100	15	42,30	0,023
4H58CTBB	170240	8-14	10-70	100	15	44,40	0,025
4H912CTBB	170260	14-20	10-70	100	15	47,50	0,027

H-MA PŘÍCHYTKA

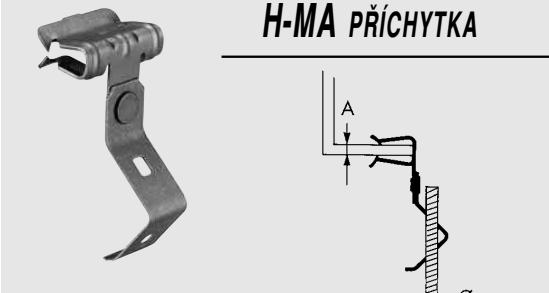

Obj.č.	A mm	Ø	Kus	Kus			
				kg/NS	Kč	kg	
P4 - EPZ							
M6MA4	173230	2-3	M6	100	60	37,80	0,025
M6MA24	173240	3-8	M6	100	60	39,00	0,025
M6MA58	173250	8-14	M6	100	60	40,30	0,027
M6MA912	173260	14-20	M6	100	60	42,00	0,030
M8MA4	173270	2-3	M8	100	60	37,80	0,025
M8MA24	173280	3-8	M8	100	70	37,80	0,025
M8MA58	173290	8-14	M8	100	70	39,00	0,027
M8MA912	173300	14-20	M8	100	70	42,00	0,030
M10MA4	173310	2-3	M10	100	70	37,80	0,025
M10MA24	173320	3-8	M10	100	70	39,00	0,025
M10MA58	173330	8-14	M10	100	70	40,30	0,027
M10MA912	173340	14-20	M10	100	70	42,00	0,030

H-Ti/T PŘÍCHYTKA



Obj.č.	A mm	Ø 1 M/mm	Ø 2 mm	Kus	Kus			
					kg/NS	Kč	kg	
P4 - EPZ								
M6Ti4	174810	2-3	M6	7	100	70	34,80	0,022
M6Ti24	174820	3-8	M6	7	100	90	36,00	0,028
M6Ti58	174830	8-14	M6	7	100	90	37,20	0,030
M6Ti912	174840	14-20	M6	7	100	90	40,30	0,032
M8Ti4	174900	2-3	M8	8,5	100	70	34,80	0,022
M8Ti24	174910	3-8	M8	8,5	100	90	36,00	0,028
M8Ti58	174920	8-14	M8	8,5	100	90	39,00	0,030
M8Ti912	174930	14-20	M8	8,5	100	90	40,80	0,032
M10Ti4	174990	2-3	M10	11	100	70	36,60	0,022
M10Ti24	175000	3-8	M10	11	100	90	37,80	0,028
M10Ti58	175010	8-14	M10	11	100	90	39,00	0,030
M10Ti912	175020	14-20	M10	11	100	90	40,80	0,032

Obj.č.	A mm	Ø 1 M/mm	Ø 2 mm	Kus	Kus			
					kg/NS	Kč	kg	
P4 - EPZ								
Ti04	160000	2-3	11	11	100	70	34,80	0,021
Ti024	160010	3-8	11	11	100	90	37,80	0,028
Ti058	160020	8-14	11	11	100	90	39,00	0,030
Ti0912	160030	14-20	11	11	100	90	40,80	0,031

H-S PŘÍCHYTKA

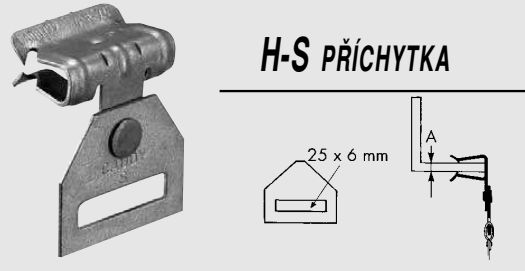

Obj.č.	A mm	Kus	Kus			
			kg/NS	Kč	kg	
P4 - EPZ						
S4	175480	2-3	100	70	40,80	0,017
S24	172030	3-8	100	90	42,70	0,025
S58	171760	8-14	100	90	43,90	0,028
S912	171770	14-20	100	90	45,10	0,029

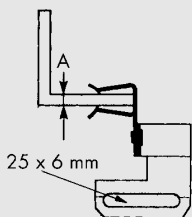
CADDY**H-SR PŘÍCHYTKA**

Obj.č.	A mm	kg/NS	Kus			
			kg/NS	Kč	kg	
P4 - EPZ						
SR4	175540	2-3	100	70	46,30	0,021
SR24	171810	3-8	100	90	48,00	0,030
SR58	175550	8-14	100	90	49,20	0,032
SR912	172020	14-20	100	90	51,10	0,034

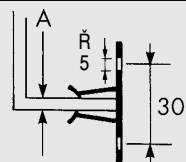
H-Di PŘÍCHYTKA

Obj.č.	A mm	kg/NS	Kus			
			kg/NS	Kč	kg	
P4 - EPZ						
4H24Di	350000	3-8	100	15	32,00	0,011

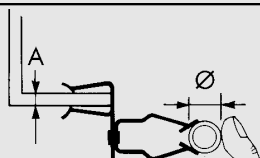
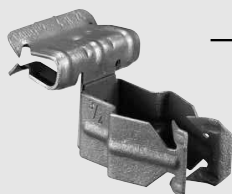
H-PSM PŘÍCHYTKA

Obj.č.	A mm	Ø mm	kg/NS	Kus			
				kg/NS	Kč	kg	
P4 - EPZ							
8P4SM	175170	2-3	18-22	100	7	40,30	0,021
8P24SM	175180	3-8	18-22	100	7	40,80	0,025
8P58SM	175190	8-14	18-22	100	7	42,30	0,029
8P912SM	175200	14-20	18-22	100	7	44,90	0,031
12P4SM	175210	2-3	22-30	100	7	40,80	0,021
12P24SM	175220	3-8	22-30	100	7	42,30	0,029
12P58SM	175230	8-14	22-30	100	7	43,50	0,031
12P912SM	175240	14-20	22-30	100	7	46,40	0,032
16P4SM	175250	2-3	30-35	100	7	47,60	0,025
16P24SM	175260	3-8	30-35	100	7	49,10	0,031
16P58SM	175270	8-14	30-35	100	7	50,30	0,033
16P912SM	175280	14-20	30-35	100	7	53,50	0,034

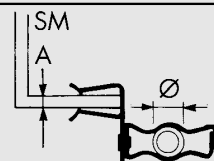
H-MSM PŘÍCHYTKA

Obj.č.	A mm	Ø mm	kg/NS	Kus			
				kg/NS	Kč	kg	
P4 - EPZ							
6M4SM	173630	2-3	14-18	100	12	43,90	0,020
6M24SM	173640	3-8	14-18	100	12	45,10	0,026
6M58SM	171980	8-14	14-18	100	12	46,30	0,028
6M912SM	173650	14-20	14-18	100	12	49,20	0,030
812M4SM	160040	2-3	18-30	100	12	43,90	0,022
812M24SM	160050	3-8	18-30	100	12	46,30	0,030
812M58SM	160060	8-14	18-30	100	12	49,20	0,031
812M912SM	160070	14-20	18-30	100	12	52,30	0,033
16M4SM	173710	2-3	30-35	100	12	50,30	0,024
16M24SM	173720	3-8	30-35	100	12	52,00	0,031
16M58SM	173730	8-14	30-35	100	12	54,70	0,033
16M912SM	173740	14-20	30-35	50	12	57,30	0,035
20M4SM	173750	2-3	35-42	50	12	61,70	0,028
20M24SM	171720	3-8	35-42	50	12	63,00	0,034
20M58SM	173770	8-14	35-42	50	12	64,70	0,037
20M912SM	173780	14-20	35-42	50	12	67,10	0,038
24M4SM	173790	2-3	42-50	50	12	67,90	0,031
24M24SM	176690	3-8	42-50	50	12	69,60	0,037
24M58SM	173800	8-14	42-50	50	12	70,80	0,040
24M912SM	173810	14-20	42-50	50	12	73,90	0,041
32M4SM	173820	2-3	50-60	50	12	75,60	0,035
32M24SM	173830	3-8	50-60	50	12	76,80	0,040
32M58SM	173840	8-14	50-60	50	12	78,00	0,043
32M912SM	173850	14-20	50-60	50	12	81,10	0,044

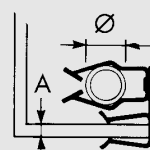
H-PiN PŘÍCHYTKA

Obj.č.	A mm	Ø mm	kg/NU	Kus			
				kg/NU	Kč	kg	
P4 - EPZ							
8P4iN	175290	2-3	18-22	100	7	43,90	0,029
8P24iN	175300	3-8	18-22	100	7	45,10	0,025
8P58iN	175310	8-14	18-22	100	7	46,30	0,029
12P4iN	175320	2-3	22-30	100	7	43,90	0,021
16P4iN	175330	2-3	30-35	100	7	52,30	0,025

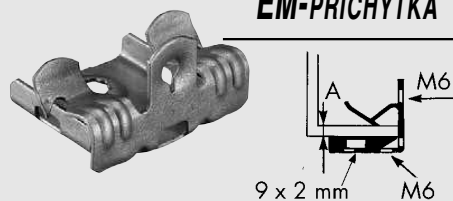
CADDY®**EM-PŘÍCHYTKA**

Obj.č.	A mm	kg/NS	Kus			
			kg/NS	Kč	kg	
P4 - EPZ						
EM24	170050	3-8	100	45	18,00	0,028
EM58	170060	8-14	100	45	19,80	0,031
EM912	170070	14-20	100	45	21,60	0,035

EM-SM PŘÍCHYTKA

Obj.č.	A mm	kg/NS	Kus			
			kg/NS	Kč	kg	
P4 - EPZ						
EM24SM	170530	3-8	100	33	28,80	0,028
EM58SM	172060	8-14	100	33	30,90	0,032
EM912SM	171850	14-20	100	33	34,40	0,038

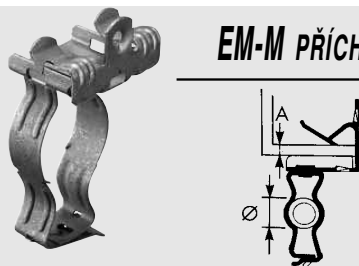
EM-M PŘÍCHYTKA

Obj.č.	A mm	Ø mm	kg/NS	Kus			
				kg/NS	Kč	kg	
P4 - EPZ							
6EM24	173550	3-8	14-18	100	33	45,60	0,035
6EM58	171750	8-14	14-18	100	33	49,20	0,039
6EM912	173560	14-20	14-18	50	33	48,70	0,044
812EM24	160120	3-8	18-30	50	33	48,70	0,036
812EM58	160130	8-14	18-30	50	33	54,00	0,041
812EM912	160140	14-20	18-30	50	33	56,40	0,046
16EM24	171740	3-8	30-35	50	33	45,10	0,040
16EM58	171490	8-14	30-35	50	33	46,60	0,043
16EM912	173570	14-20	30-35	50	33	62,40	0,049
20EM24	171800	3-8	35-42	50	33	54,10	0,042
20EM58	171950	8-14	35-42	50	33	55,50	0,047
20EM912	173580	14-20	35-42	50	33	72,00	0,052
24EM24	171960	3-8	42-50	50	33	75,60	0,044
24EM58	171970	8-14	42-50	50	33	78,70	0,047
24EM912	173590	14-20	42-50	50	33	82,80	0,053
32EM24	173600	3-8	50-60	50	33	84,00	0,048
32EM58	173610	8-14	50-60	50	33	88,80	0,052
32EM912	173620	14-20	50-60	50	33	93,10	0,060

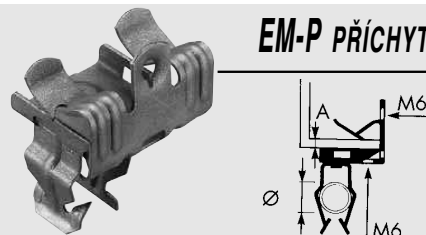
EM-P PŘÍCHYTKA

Obj.č.	A mm	Ø mm	kg/NU	Kus			
				kg/NU	Kč	kg	
P4 - EPZ							
8EP24	172150	3-8	18-22	100	11	46,40	0,034
8EP58	172160	8-14	18-22	100	11	47,60	0,036
8EP912	175100	14-20	18-22	50	11	50,30	0,042
12EP24	175110	3-8	22-30	100	11	47,60	0,035
12EP58	175120	8-14	22-30	100	11	49,10	0,038
12EP912	175130	14-20	22-30	50	11	56,40	0,044
16EP24	175140	3-8	30-35	100	11	54,70	0,036
16EP58	175150	8-14	30-35	50	11	57,30	0,041
16EP912	175160	14-20	30-35	50	11	60,30	0,046

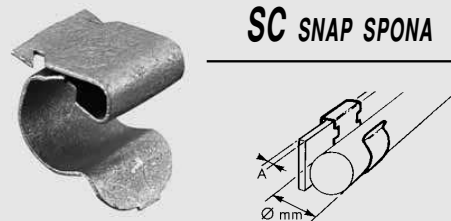
SC SNAP SPONA

Obj.č.	A mm	Ø mm	kg/NS	Kus			
				PG	Kč	kg	
P1 (P4)							
24SC67	187510	2-4	6-7	100		3,60	0,004
24SC78	187710	2-4	7-8	100		3,60	0,004
24SC89	187530	2-4	8-9	100		3,60	0,004
24SC910	187750	2-4	9-10	100		3,60	0,004
24SC1011	187550	2-4	10-11	100		3,70	0,005
24SC1214	187570	2-4	12-14	100		3,70	0,005
24SC1518	187590	2-4	15-18	100	9	4,20	0,006
24SC1924	187610	2-4	19-24	100	11-13,5-16	5,50	0,007
24SC2530	187630	2-4	25-32	100	21	6,60	0,008
P1 (P4)							
47SC67	187500	4-7	6-7	100		3,60	0,004
47SC78	187720	4-7	7-8	100		3,60	0,004
47SC89	187520	4-7	8-9	100		3,60	0,004
47SC910	187760	4-7	9-10	100		3,60	0,004
47SC1011	187540	4-7	10-11	100		3,70	0,005
47SC1214	187560	4-7	12-14	100		3,70	0,005
47SC1518	187580	4-7	15-18	100	9	4,20	0,006
47SC1924	187600	4-7	19-24	100	11-13,5-16	5,50	0,007
47SC2530	187620	4-7	25-32	100	21	6,60	0,008
P1 (P4)							
812SC67	187640	8-12	6-7	100		3,60	0,005
812SC78	187730	8-12	7-8	100		3,60	0,005
812SC89	187650	8-12	8-9	100		3,60	0,005
812SC910	187770	8-12	9-10	100		3,60	0,005
812SC1011	187660	8-12	10-11	100		3,70	0,005
812SC1214	187670	8-12	12-14	100		3,70	0,006
812SC1518	187680	8-12	15-18	100	9	4,20	0,006
812SC1924	187690	8-12	19-24	100	11-13,5-16	5,50	0,007
812SC2530	187700	8-12	25-32	100	21	6,60	0,009

CADDY®



SCA SNAP SPONA

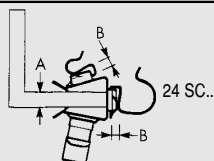

Obj.č.	A mm	B mm	Kus	Kus		
				Kč	kg	
P4 - EPZ						
SCA	160510	13-20	2-4	100	12,00	0,012



LF 2/3 SNAP SPONA

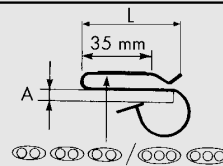

Obj.č.	A mm	L mm	Kus	Kus		
				Kč	kg	
P1						
LF2	187400	5-12	45	100	27,00	0,010
LF3	187410	12-20	53	100	30,60	0,010

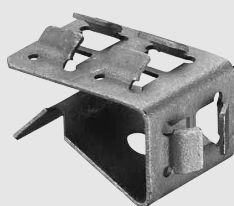

SCB SNAP SPONA

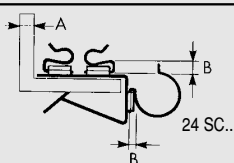

Obj.č.	A mm	B mm	Kus	Kus		
				Kč	kg	
P4						
SCB312	188080	3-12	2-4	100	15,00	0,009
SCB1220	188090	12-20	2-4	100	15,60	0,009

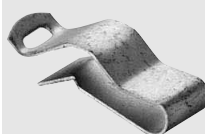

LF 4/5 SNAP SPONA

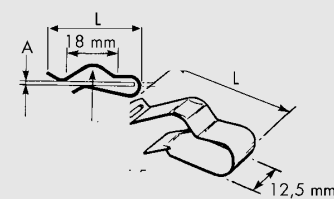

Obj.č.	A mm	L mm	Kus	Kus		
				Kč	kg	
P1						
LF4	187420	3-6	42	100	17,40	0,007
LF5	187430	6-12	49	100	17,40	0,008



HK SNAP SPONA

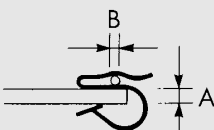

Obj.č.	A mm	B mm	Kus	Kus		
				Kč	kg	
P1						
HK21	187440	1,5-4,5	4,2-6,5	100	22,80	0,004
HK22	187450	4-8	4,2-6,5	100	22,80	0,004
HK23	187460	8-11	4,2-6,5	100	22,80	0,002



LR SNAP SPONA

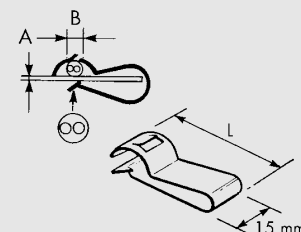

Obj.č.	A mm	B mm	L mm	Kus	Kus		
					Kč	kg	
P1							
LR1	187370	3-6	8-15	36	100	19,20	0,006
LR2	187380	6-12	8-15	36	100	19,20	0,007



87 SNAP SPONA

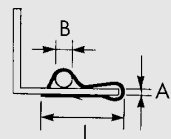

Obj.č.	A mm	B mm	L mm	Kus	Kus		
					Kč	kg	
P1							
87182	188190	5	10	40	100	19,20	0,005
87186	188200	6	8	65	100	19,20	0,005



LB3B SNAP SPONA

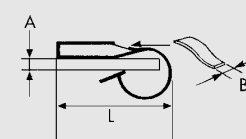

Obj.č.	A mm	B mm	L mm	Kus	Kus		
					Kč	kg	
P1							
LB3B	187390	12-20	<8	52	100	31,80	0,019

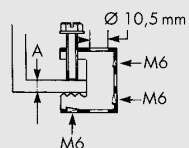
CADDY**ŠROUBOVACÍ PŘÍCHYTKA EBC**

Obj.č.	A mm	M	Kus kg/NS	Kus	
				Kč	kg

P4 - EPZ

EBC	170380	<16	6	100	45	33,60	0,021
-----	--------	-----	---	-----	----	-------	-------

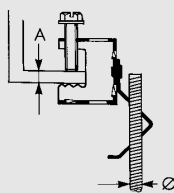
**ŠROUBOVACÍ PŘÍCHYTKA EBC-MA**

Obj.č.	A mm	Ø	Kus kg/NS	Kus	
				Kč	kg

P4 - EPZ

EBCM6MA	172990	<16	M6	100	25	63,60	0,031
EBCM8MA	173000	<16	M8	100	25	63,60	0,032
EBCM10MA	173010	<16	M10	100	25	67,90	0,032

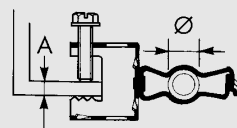
**ŠROUBOVACÍ PŘÍCHYTKA EBC-MSM**

Obj.č.	A mm	Ø	Kus kg/NS	Kus	
				Kč	kg

P4 - EPZ

EBC6MSM	172650	<16	14-18	100	11	64,30	0,035
EBC812MSM	160180	<16	18-30	100	11	66,70	0,037
EBC16MSM	172660	<16	30-35	100	11	72,70	0,039
EBC20MSM	172670	<16	35-42	50	11	80,40	0,043
EBC24MSM	172680	<16	42-50	50	11	85,90	0,044
EBC32MSM	172690	<16	50-60	50	11	94,30	0,049

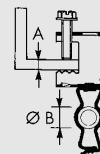
**ŠROUBOVACÍ PŘÍCHYTKA EBC-M**

Obj.č.	A mm	Ø	Kus kg/NS	Kus	
				Kč	kg

P4 - EPZ

EBC6M	172580	<16	14-18	100	45	68,40	0,035
EBC812M	160200	<16	18-30	100	45	63,60	0,037
EBC16M	172590	<16	30-35	100	45	74,40	0,039
EBC20M	172600	<16	35-42	50	45	77,50	0,042
EBC24M	172610	<16	42-50	50	45	87,10	0,044
EBC32M	172620	<16	50-60	50	45	93,10	0,049

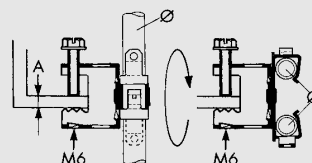
**ŠROUBOVACÍ PŘÍCHYTKA EBC-MAC2**

Obj.č.	A mm	Ø	Kus kg/NS	Kus	
				Kč	kg

P4 - EPZ

EBCMAC2	172980	<16	12,5-14,5	100		55,20	0,034
---------	--------	-----	-----------	-----	--	-------	-------

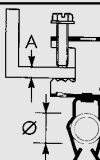
**ŠROUBOVACÍ PŘÍCHYTKA EBC-P**

Obj.č.	A mm	Ø	Kus kg/NU	Kus	
				Kč	kg

P4 - EPZ

EBC8P	172700	<16	18-22	100	11	63,00	0,034
EBC12P	172710	<16	22-30	100	11	66,70	0,035
EBC16P	172720	<16	30-35	100	11	70,80	0,038

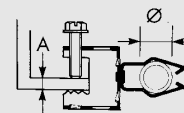
**ŠROUBOVACÍ PŘÍCHYTKA EBC-PSM**

Obj.č.	A mm	Ø	Kus kg/NU	Kus	
				Kč	kg

P4

EBC8PSM	172730	<16	18-22	100	7	60,30	0,034
EBC12PSM	172740	<16	22-30	100	7	61,70	0,035
EBC16PSM	172750	<16	30-35	100	7	68,60	0,038

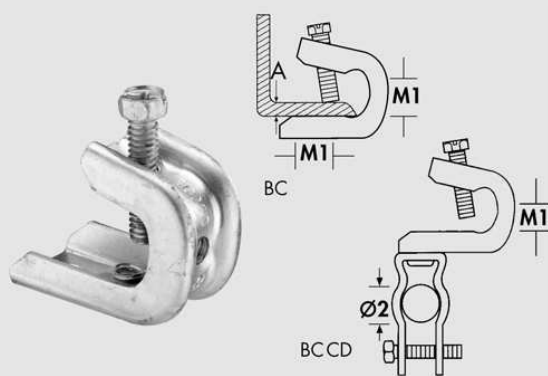
CADDY®**BC 200**

Obj.č.	M 1	A mm	Kus		
			kg/NS	Kč	kg

P1

BC200	181180	M6	<16	100	55	30,60	0,050
-------	--------	----	-----	-----	----	-------	-------

Obj.č.	M1	∅ 2 mm		A mm	Kus		
		min.	max.		kg/NS	Kč	kg

P1

BC200/CD0B	182210	M6	17	22	<16	50	43,20	0,076
BC200/CD1B	182220	M6	19	25	<16	50	45,10	0,086
BC200/CD2B	182230	M6	25	33	<16	50	52,30	0,114
BC200/CD2.5B	182240	M6	31	38	<16	50	55,20	0,131
BC200/CD3B	182250	M6	36	43	<16	50	58,30	0,148

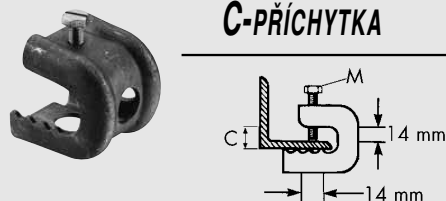
C-PŘÍCHYTKA

Obj.č.	C mm	M mm	Kus		
			kg/NS	Kč	kg

P3

C20	336100	20	6x25	100	110	93,90	0,092
C30	336110	30	8x30	100	110	133,90	0,140
C45	336120	45	8x30	50	110	157,90	0,200

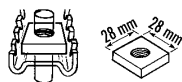
PROFILOVÁ MATICE SM

Obj.č.	M mm	Kus		
		kg/NS	Kč	kg

P3

SM6	336160	6	100	21,00	0,032
SM8	336170	8	100	21,00	0,036

PODLOŽKA NA OCHRANU LAKOVANÉHO POVRCHU

Obj.č.	M mm	Kus		
		kg/NS	Kč	kg

P3

SPP6	336200	6	100	12,00	0,44
SPP8	336210	8	100	12,00	0,44

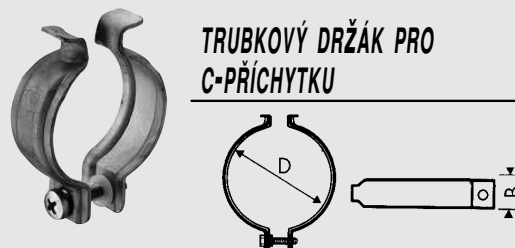
TRUBKOVÝ DRŽÁK PRO C-PŘÍCHYTKU

Obj.č.	D mm	B mm	Kus

P3

CR17	336300	16-20	16	200	25/55	25,20	0,012
CR21	336310	20,4-25	16	100	25/55	28,20	0,020
CR28	336320	26,9-31,8	16	100	25/55	28,20	0,024
CR37	336330	33,7-38	20	50	25/55	36,00	0,036
CR42	336340	40-44,5	20	50	25/55	37,20	0,046
CR48	336350	47-51	20	50	25/55	43,90	0,056
CR60	336360	59,2-63,5	20	25	25/55	49,20	0,068

TKN

Obj.č.	mm	Kus		
		kg/NS	Kč	kg

P1

TKN M6	386805	M6	140	120	48,00	0,09
TKN 8	389500	9	100	120	54,00	0,09
TKN M8	386810	M8	100	120	54,00	0,09
TKN 10	389510	11	100	250	57,10	0,15
TKN M10	386820	M10	100	250	57,10	0,15
TK 12	389520	13	80	350	72,00	0,17
TK M12	386830	M12	80	350	72,00	0,17

ZAJIŠŤOVACÍ PÁSEK

Obj.č.	B x L mm	Kus		
		kg/NS	Kč	kg

P1

SL 25x2,5x350	590240	25x350	50	43,20	0,1734
---------------	--------	--------	----	-------	--------

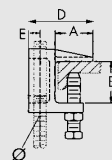
BTK

Obj.č.	∅	A mm	B mm	D mm	E mm	Kus		
						kg/NS	Kč	kg

P1

BTK M10	389890	M10	21,4	31,8	48,4	8,7	50	280	84,00	0,17
BTK M12	388890	M12	18,9	31,8	48,4	9,5	50	510	106,30	0,28

CADDY®

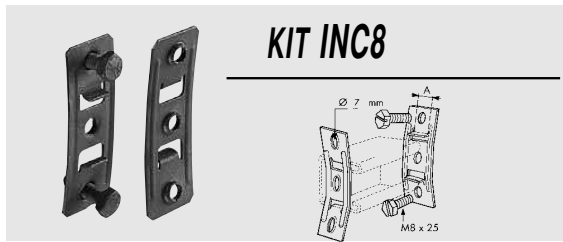

KIT INC8

Obj.č.	A mm	Kus	kg/NS		
			Kč	kg	
P4 - EPZ					
INC8	336290	13 100	45	206,50	0,085

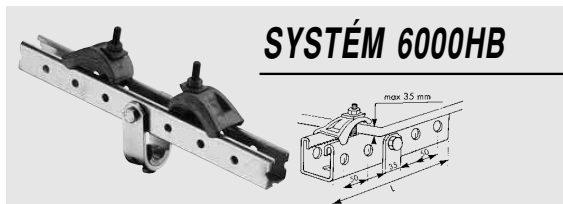

SYSTEM 6000HB

Obj.č.	L mm	Kus	kg/NS			
			Kč	kg		
P1 + P3						
6001HB	336000	300	1	300	988,10	2,28
6002HB	336010	400	1	230	1090,20	2,56
6003HB	336020	500	1	180	1141,20	2,85
SWIVEL 6000HB	388350		1		427,90	2,85

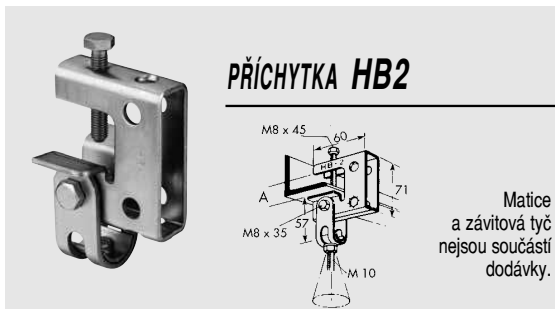

PŘÍCHYTKA HB2

Matice a závitová tyč nejsou součástí dodávky.

Obj.č.	Ø mm	Kus	kg/NS		
			Kč	kg	
P1					
HB2	336030	< 24 50	170-250°	162,70	0,30
P3					
HB2-3	336040	< 24 50	170-250°	191,50	10,30

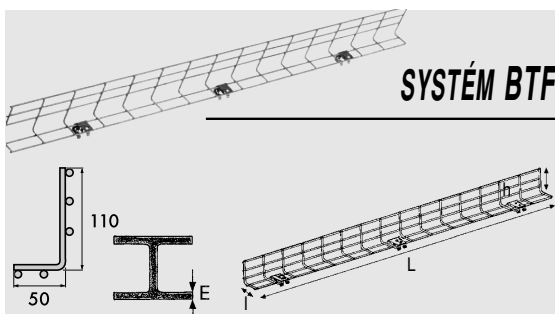

SYSTEM BTF

Obj.č.	E mm	L x l x h mm	Kus	kg/NS	
				Kč	kg
P1 (P4-EPZ)					
BTF24	160820	3-8 1500x50x110	10	526,50	1,580
BTF58	160830	8-14 1500x50x110	10	515,40	1,590
BTF912	160840	14-20 1500x50x110	10	535,50	1,610

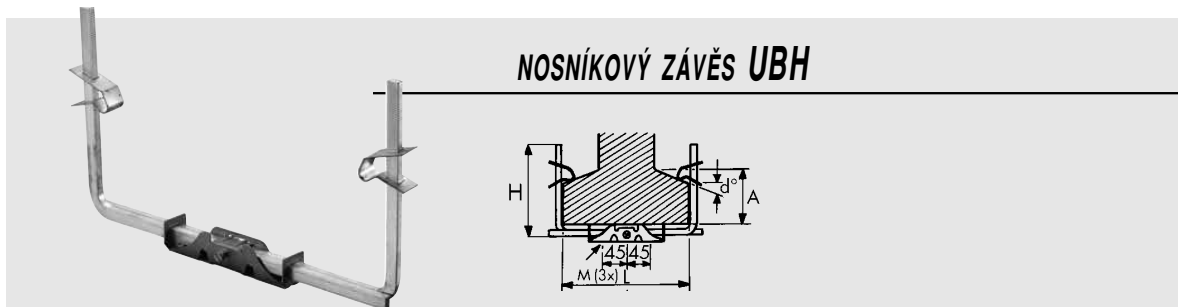

NOSNÍKOVÝ ZÁVĚS UBH

Obj.č.	A mm	H mm	L mm	M	d°	Kus	kg/NS			
							Kč	kg		
P1										
UBH 35 M6	190530	3-110	170	200-350	M6	0-20°/20-40°	20	75/50	368,60	0,82
UBH 35 M8	190490	3-110	170	200-350	M8	0-20°/20-40°	20	75/50	368,60	0,82
UBH 50 M6	190540	3-150	210	300-500	M6	0-20°/20-40°	20	75/50	419,00	1,00
UBH 50 M8	190500	3-150	210	300-500	M8	0-20°/20-40°	20	75/50	419,00	1,00

* Podle směru zatížení

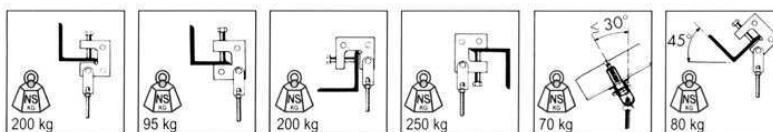

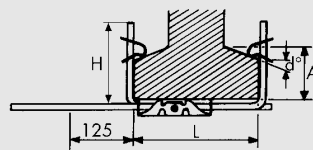
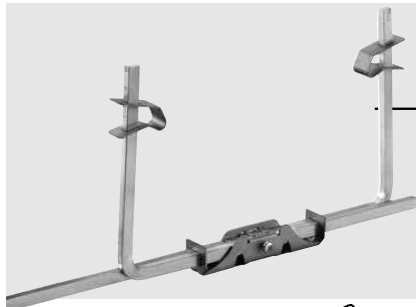
CADDY®**NOSNÍKOVÝ ZÁVĚS UBHT**

Obj.č.	A mm	H mm	L mm	Úhel d°	Kus	kg			
						Kč	kg		
P1									
UBHT 35	190510	3-110	170	200-350	0-20°/20-40°	20	100/50	396,80	0,980
UBHT 50	190520	3-150	210	350-500	0-20°/20-40°	20	100/50	436,50	1,220

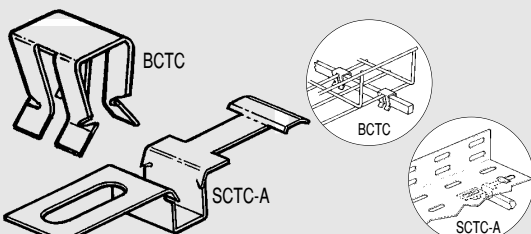
PŘÍSLUŠENSTVÍ UBH-UBHT

Obj.č.	Kus	kg		
		Kč	kg	
P4 - EPZ				
SCTC-A	190600	100	10,80	0,005
BCTC	190620	100	6,60	0,004

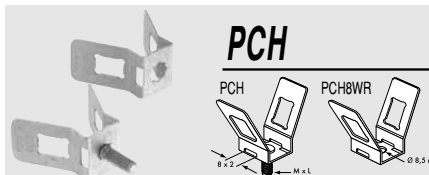
PCH

Obj.č.	M x L Ø mm	Kus	kg		
			Kč	kg	
P4 - EPZ					
PCH8WR	190650	8,5	100	10,80	0,100
PCH6	190630	M6x16	100	15,60	0,110
PCH8	190640	M8x15	100	19,80	0,120

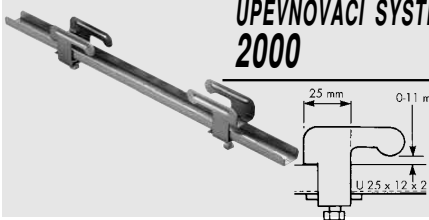
UPEVNĚVACÍ SYSTÉM 2000

Obj.č.	L mm	Kus	kg		
			Kč	kg	
P1					
2150	570130	150	25	190,90	0,24
2200	570140	200	25	196,90	0,25
2250	570150	250	25	206,50	0,29
2300	570160	300	25	214,90	0,32
2350	570170	350	25	220,90	0,35
2400	570180	400	25	231,70	0,40

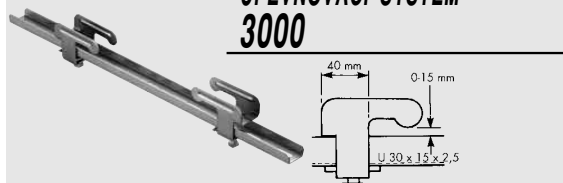
UPEVNĚVACÍ SYSTÉM 3000

Obj.č.	L mm	Kus	kg		
			Kč	kg	
P1					
3300	570410	300	25	303,80	0,56
3400	570420	400	25	333,20	0,66
3500	570430	500	25	368,60	0,77
3600	570440	600	25	393,80	0,87

Obj.č.	L mm	Kus	kg		
			Kč	kg	
P1					
3001	570560	300	25	103,90	0,28
3002	570570	400	25	133,90	0,37
3003	570580	500	25	168,70	0,47
3004	570590	600	25	193,90	0,57

Obj.č.	Kus	kg		
		Kč	kg	
P1				
3025	570500	50	99,70	0,29

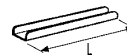

Obj.č.	L mm	Kus	kg		
			Kč	kg	
P1					
2001	570300	150	25	50,40	0,10
2002	570310	200	25	56,40	0,13
2003	570320	250	25	66,00	0,16
2004	570330	300	25	74,40	0,18
2005	570340	350	25	80,40	0,23
2006	570350	400	25	91,20	0,25

Obj.č.	Kus	kg		
		Kč	kg	
P1				
2025	570240	50	70,30	0,13

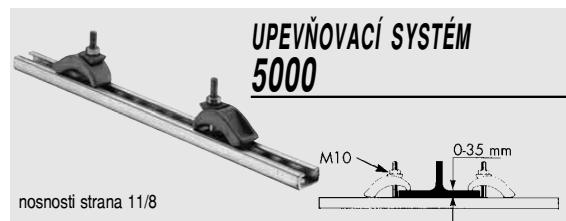
CADDY®

Obj.č.	L mm	Kus Kč	kg		
				P3	
5130	335000	300	1	694,60	1,4
5140	335010	400	1	734,20	1,6
5150	335020	500	1	769,00	1,8
5160	335030	600	1	800,80	2,0
5170	335040	800	1	870,50	2,3

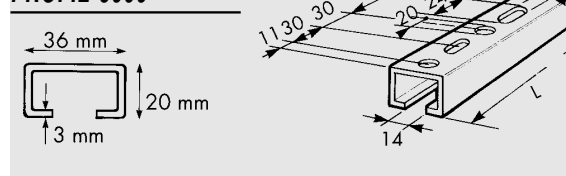
PROFIL 5000

Obj.č.	L mm	Kus Kč	kg		
				P3	
5101	335500	300	10	128,50	0,6
5102	335510	400	10	168,70	0,8
5103	335520	500	10	203,50	1,0
5104	335530	600	10	235,30	1,2
5105	335540	800	10	305,00	1,5
5106	335550	1000	10	390,80	1,9
5107	335560	2000	10	635,80	3,8
5109	335570	3000	10	913,70	5,8
5110	335580	6000	10	1827,40	11,5

SVORNÍK SYSTÉMU 5000

Obj.č.	L mm	Kus Kč	kg	
				P3
5120	335100	20	268,90	0,37

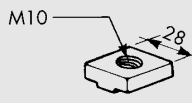
PROFILOVÁ MATICE SYSTÉMU 5000

Obj.č.	L mm	Kus Kč	kg	
				P3
5190	335150	50	66,00	0,057

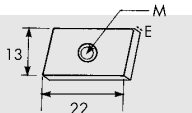
PROFILOVÁ MATICE

Obj.č.	M	E mm	Kus Kč	kg		
					P3	
iM6	335170	6	4,5	100	21,60	0,011
iM8	335180	8	6	100	22,20	0,013
iM10	335190	10	7,5	100	27,60	0,017



Obj.č.	L mm	Kus Kč	kg		
				P3	
6130	330000	300	1	955,10	1,05
6140	330010	400	1	1015,20	1,40
6150	330020	500	1	1111,20	1,75
6160	330030	600	1	1171,30	2,10
6180	330040	800	1	1314,70	2,80

DVOJITÝ PROFIL 41 x 21 mm x 2,5 mm

Obj.č.	L mm	Kus Kč	kg		
				P3	
6530	330100	300	1	1041,00	2,56
6540	330110	400	1	1158,60	3,08
6550	330120	500	1	1267,30	3,60
6560	330130	600	1	1359,10	4,12
6580	330140	800	1	1632,90	5,16

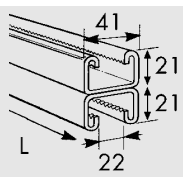
**DVOJITÝ PROFIL
41 x 21 mm x 2,5 mm**

Obj.č.	L mm	Kus Kč	kg/1		
				P3	
6101	330200	300	10	375,10	1,05
6102	330210	400	10	346,40	1,40
6103	330220	500	10	578,40	1,75
6104	330230	600	10	501,90	2,10
6105	330240	800	10	645,90	2,80
6106	330250	1000	10	754,60	3,50
6107	330260	2000	5	1482,60	7,00
6108/DDC 30-3	310101	3000	5	1779,40	10,50
6110/DDC 60-3	310111	6000	5	3455,40	21,60

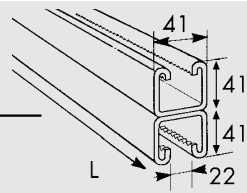
**DVOJITÝ PROFIL
41 x 41 mm x 2,5 mm**

Obj.č.	L mm	Kus Kč	kg		
				P3	
6501	330380	300	10	372,80	1,56
6502	330390	400	10	490,50	2,03
6503	330400	500	10	599,10	2,60
6504	330410	600	10	691,00	3,12
6505	330420	800	10	964,70	4,16
6506	330430	1000	10	1107,60	5,20
6507	330440	2000	5	1329,70	10,40
6508/AAC 30-3	310221	3000	5	2029,10	15,60
6510/AAC 60-3	310231	6000	5	4058,80	31,20

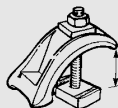
CADDY®**SVORNÍK SYSTÉMU 6000**

Obj.č.	Kus	Kč	kg
6120	330600	20	1317,60 0,58

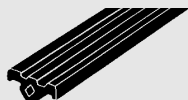
GUMOVÁ VLOŽKA PRO SYSTÉM 5000+6000

Obj.č.	Kus	Kč	kg
5195	335990	20 m	425,30 4,60
6195	335980	20 m	425,30 5,80

PROFILOVÁ MATICE

UM

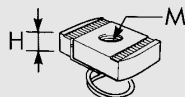
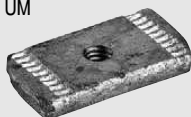

UA



UD

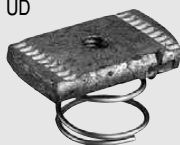

Obj.č.	M mm	H mm	Kus	Kč	kg
UM506 P3	315000	6	5	100	13,80 0,03
UM608 P3	315010	8	6	100	15,00 0,03
UM810 P3	315020	10	8	100	16,80 0,04
UM812 P3	315030	12	8	100	18,00 0,03

UD506 P3	315040	6	5	100	18,60 0,03
UD608 P3	315050	8	6	100	19,80 0,03
UD810 P3	315060	10	8	100	21,00 0,04
UD812 P3	315070	12	8	100	22,20 0,04

UA506 P3	315080	6	5	100	18,60 0,03
UA608 P3	315090	8	6	100	19,80 0,03
UA810 P3	315100	10	8	100	21,00 0,04
UA812 P3	315110	12	8	100	22,20 0,04

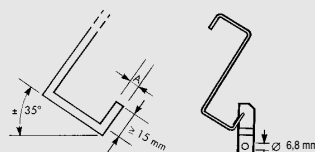
122 PŘÍCHYTKA

Obj.č.	A mm	Kus	kg/NS	Kč	kg
122	171690	2,8	100	45	21,00 1,06

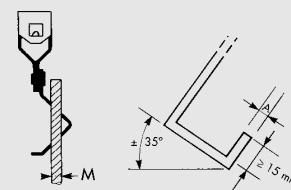
122-MA PŘÍCHYTKA

Obj.č.	A mm	M	Kus	kg/NS	Kč	kg
122 M6MA	174680	2,8	M6	100	45	43,90 0,018
122 M8MA	174690	2,8	M8	100	45	43,90 0,019
122 M10MA	174700	2,8	M10	100	45	43,90 0,021

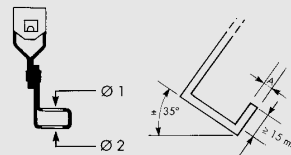
122-TI PŘÍCHYTKA

Obj.č.	A mm	Ø 1 M	Ø 2 mm	Kus	kg/NS	Kč	kg
122M6Ti	174890	2,8	M6	7	100	45	53,50 0,025
122M8Ti	174980	2,8	M8	8,5	100	45	53,50 0,025
122M10Ti	175070	2,8	M10	11	100	45	53,50 0,025

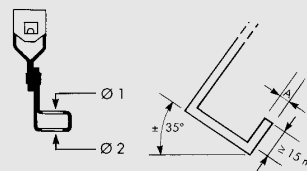
122-T10 PŘÍCHYTKA

Obj.č.	A mm	Ø 1 mm	Ø 2 mm	Kus	kg/NS	Kč	kg
122 T10	160240	2,8	11	11	100	45	42,00 0,025

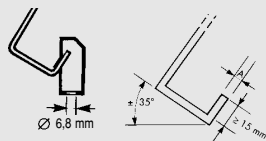
CADDY**123 PŘÍCHYTKA**

Obj.č.	A mm	Kus	Kus			
			kg/NS	Kč	kg	
P4 - EPZ						
123	171700	< 2,8	100	45	20,40	0,010

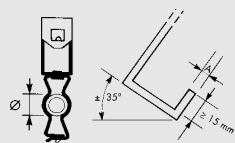
123-M PŘÍCHYTKA

Obj.č.	A mm	Ø mm	Kus	Kus			
				kg/NS	Kč	kg	
P4 - EPZ							
123 6M	174760	< 2,8	14-18	100	45	55,20	0,024
123 812M	160420	< 2,8	18-30	100	45	56,40	0,028
123 16M	174790	< 2,8	30-35	100	45	59,50	0,029
123 20M	177760	< 2,8	35-42	50	45	70,80	0,031

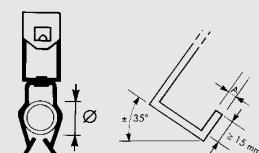
123-P PŘÍCHYTKA

Obj.č.	A mm	Ø mm	Kus	Kus			
				kg/NS	Kč	kg	
P4 - EPZ							
123 8P	176720	< 2,8	18-22	100	11	53,50	0,022
123 12P	176730	< 2,8	22-30	100	11	56,40	0,022
123 16P	176740	< 2,8	30-35	100	11	59,50	0,026

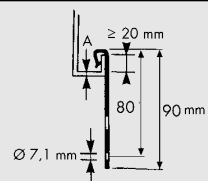
VF PŘÍCHYTKA

Obj.č.	A mm	Kus	Kus			
			kg/NS	Kč	kg	
P4 - EPZ						
VF14	179850	1,5-6	100	60	24,60	0,010

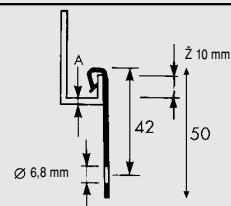
J PŘÍCHYTKA

Obj.č.	A mm	Kus	Kus			
			kg/NS	Kč	kg	
P4 - EPZ						
J1	170370	1,5-4	100	70	15,60	0,009
J2	171590	4-6,5	100	70	15,60	0,009

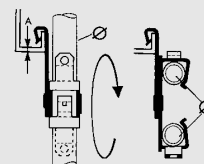
J-MAC2 PŘÍCHYTKA

Obj.č.	A mm	Ø mm	Kus	Kus		
				Kč	kg	
P4 - EPZ						
J1MAC 2 P4	173480	1,5-4	125-14,5	100	33,00	0,021
J2MAC2 P4	172970	4-6,5	125-14,5	100	33,00	0,021

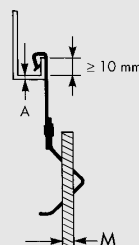
J-MA PŘÍCHYTKA

Obj.č.	A mm	M	Kus	Kus			
				kg/NS	Kč	kg	
P4 - EPZ							
M6MAJ1	173350	1,5-4	M6	100	60	37,80	0,019
M8MAJ1	173360	1,5-4	M8	100	70	37,80	0,019
M10MAJ1	173370	1,5-4	M10	100	70	37,80	0,019
M6MAJ2	173380	4-6,5	M6	100	60	37,80	0,019
M8MAJ2	173390	4-6,5	M8	100	70	37,80	0,019
M10MAJ2	173400	4-6,5	M10	100	70	37,80	0,019

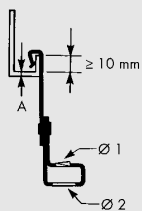
CADDY®**J-TI PŘÍCHYTKA**

Obj.č.	A mm	$\varnothing 1$ M	$\varnothing 2$ mm	kg/NS	Kus	
					Kč	kg

P4 - EPZ

M6TiJ1	174870	1,5-4	M6	7	100	70	42,00	0,025
M8TiJ1	174960	1,5-4	M8	8,5	100	70	42,00	0,025
M10TiJ1	175050	1,5-4	M10	11	100	70	42,00	0,024
M6TiJ2	174880	4-6,5	M6	7	100	70	42,00	0,025
M8TiJ2	174970	4-6,5	M8	8,5	100	70	42,00	0,025
M10TiJ2	175060	4-6,5	M10	11	100	70	42,00	0,024

C-ES PŘÍCHYTKA

Obj.č.	\varnothing mm	kg/NS	Kus	
			Kč	kg

P4 - EPZ

C 12ES	337000	6-12	100	24,60	0,027
C 16ES	337010	12-16	100	27,00	0,034
C 20ES	337020	16-20	100	27,60	0,040
C 24ES	337030	20-24	100	28,80	0,050
C 28ES	337040	24-28	100	30,60	0,060
C 32ES	337050	28-32	100	34,80	0,070
C 36ES	337060	32-36	100	42,00	0,085
C 40ES	337070	36-40	100	46,30	0,095
C 44ES	337080	40-44	100	49,20	0,105
C 48ES	337090	44-48	100	50,40	0,120
C 52ES	337100	48-52	50	53,50	0,135
C 56ES	337110	52-56	50	59,50	0,150
C 60ES	337120	56-60	50	64,80	0,165
C 64ES	337130	60-64	50	69,60	0,185
C 70ES	337140	64-70	50	85,20	0,205
C 76ES	337150	70-76	25	118,90	0,225
C 82ES	337160	76-82	25	124,30	0,225
C 88ES	337170	82-88	25	133,30	0,250
C 94ES	337180	88-94	25	159,10	0,270
C100ES	337190	94-100	25	168,10	0,315

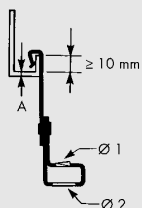
J-T PŘÍCHYTKA

Obj.č.	A mm	$\varnothing 1-2$ mm	kg/NS	Kus	
				Kč	kg

P4 - EPZ

T10J1	160220	1,5-4	11	100	70	39,00	0,026
T10J2	160230	4-6,5	11	100	70	39,00	0,026

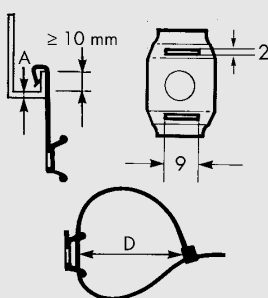
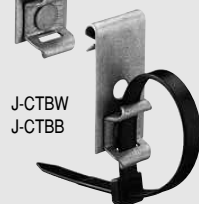
J-CT/CTB PŘÍCHYTKA

CTBB = černý pásek
CTBW = bílý pásek

Obj.č.	A mm	D mm	kg/NS	Kus	
				Kč	kg

P4 - EPZ

J1CT	170610	1,5-4	50	15	37,80	0,011	
J2CT	170350	4-6,5	50	15	37,80	0,011	
J1CTBW	170360	1,5-4	10-70	100	15	42,00	0,019
J2CTBW	170390	4-6,5	10-70	100	15	42,00	0,019
J1CTBB	170410	1,5-4	10-70	100	15	42,00	0,019
J2CTBB	170440	4-6,5	10-70	100	15	42,00	0,019

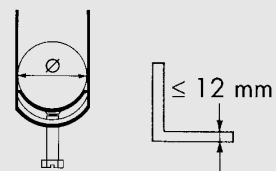
C-EU PŘÍCHYTKA

Obj.č.	\varnothing mm	kg/NS	Kus	
			Kč	kg

P3

C 12EU	337300	6-12	100	22,80	0,026
C 16EU	337310	12-16	100	24,60	0,030
C 20EU	337320	16-20	100	25,20	0,036
C 24EU	337330	20-24	100	27,00	0,042
C 28EU	337340	24-28	100	28,80	0,048
C 32EU	337350	28-32	100	31,80	0,065
C 36EU	337360	32-36	100	36,00	0,074
C 40EU	337370	36-40	100	40,30	0,079
C 44EU	337380	40-44	100	45,10	0,099
C 48EU	337390	44-48	100	46,30	0,105
C 52EU	337400	48-52	50	50,40	0,126
C 56EU	337410	52-56	50	53,50	0,136
C 60EU	337420	56-60	50	59,50	0,160
C 64EU	337430	60-64	50	62,40	0,190
C 70EU	337440	64-70	50	88,30	0,210
C 76EU	337450	70-76	25	104,50	0,220
C 82EU	337460	76-82	25	111,70	0,235
C 88EU	337470	82-88	25	123,10	0,250
C 94EU	337480	88-94	25	150,70	0,275
C100EU	337490	94-100	25	162,10	0,310